

HUISMAN PRODUCT BROCHURE

OFFSHORE WIND



ABOUT HUISMAN

Huisman is a worldwide operating company with extensive experience in the design and manufacturing of heavy construction equipment for world's leading companies in the oil & gas, renewables and leisure markets. Our product range can be divided into six main categories: Cranes, Pipelay Equipment, Drilling Equipment, Winches, Vessel Designs and Specials. Our projects vary from stand-alone to highly engineered and integrated systems, from concept to installation and life time support.

ONE STOP SHOP

Huisman has an extensive product portfolio covering the installation scope of wind turbines. The products range from spreaders, piling hammers and pile handling tools up to large capacity cranes. New technology or custom made products can be developed by our innovative engineering department on request.

GLOBAL OPERATIONS

A global market requires global and local solutions. Therefore, Huisman has expanded its engineering and production capacity from Schiedam, The Netherlands, to Sviadnov, Czech Republic,

in 1997 and in 2007 to Fujian, China. The newest production facility in Santa Catarina, Brazil, is operational since 2015. Generating over 115,000m² of total production surface. All facilities play an important role in the Huisman production force ever since.

For additional local sales, engineering and service support Huisman holds offices in Rio de Janeiro (Brazil), Houston (USA), Perth (Australia), Bergen (Norway) and Singapore.

QUALITY

The equipment delivered by Huisman is often the critical main equipment onboard and its reliability is of utmost importance



to our clients. Delivering high quality products has therefore been a key company value since our establishment. As a result, our equipment is internationally known for its high quality and reliability during operations. It meets the most stringent performance criteria and is certified by recognised authorities such as Lloyd's, DNV, ABS, TÜV, API, etc.

SERVICE

A dedicated worldwide operating service team of skilled professionals is on stand-by to provide advice, training and service support before, during and after installation and delivery. Our service network is managed from Huisman in The Netherlands and our local service offices in Navegantes (Brazil), Houston (USA), Perth (Australia) and Singapore are on stand-by to provide service support on location as well as by remote access.

TRAINING

Huisman founded the Huisman Academy in 2011. This Schiedam-based training facility is used to support Huisman clients in operating and maintaining their equipment in the most effective and safe way.

SAFETY, HEALTH AND ENVIRONMENT

We have high values on being a responsible company. Therefore, the safety, environmental and health impact of our operations is a priority within all stages of our projects.

RELIABLE PARTNER

Due to our strong belief in long lasting partnerships with our clients, our commitment to finding new technical solutions and our dedication to delivering turnkey projects, we are internationally valued as a solid, reliable partner. Our extensive track record and the large number of long-lasting client relationships prove that we deliver state-of-the-art equipment, fully tested, within schedule and ready for commercial operation.

TURNKEY DELIVERY

Our in-house design and engineering expertise in combination with our production, testing, commissioning and installation facilities, enable us to deliver custom-designed equipment on a turnkey basis.

INNOVATIVE SOLUTIONS

We are constantly working on new solutions and systems, which we believe add value to the market's existing technologies. These innovations have been implemented into many of our products. As we have extensive operational experience with a wide variety of heavy construction equipment, we are able to use the best solutions for new products and projects. Our internal disciplines include Mechanical, Structural, Naval, Hydraulical, Electrical and Software Engineering.



3,300mt Heavy Lift Vessel Rambiz (Scaldis) at work

OFFSHORE WIND

UPENDING

UPEND TOOL

The upend tool is the interface between the crane hook and a monopile. It engages the flange at the end of the monopile to act as a hoisting point for upending or lifting the monopile. The connection to the monopile is secured with hydraulically operated locking pins. The upend tool is equipped with a local power pack and is controlled by radio remote control.

FEATURES

- Adjustable to a range of diameters
- Suitable for handling Fistuca's pile hammer
- Radio remote control
- Powered by onboard powerpack

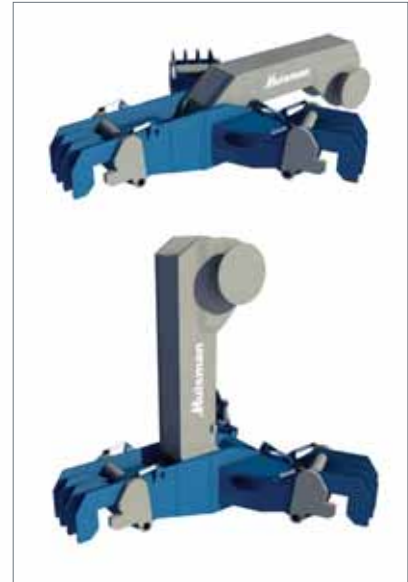

MOTION COMPENSATED GRIPPER

The motion compensated gripper enables piling from a floating vessel. It compensates the vessel motions and keeps the pile in position with high accuracy.

The gripper can also double as an upend stool facilitating pile handling and saving deck space.

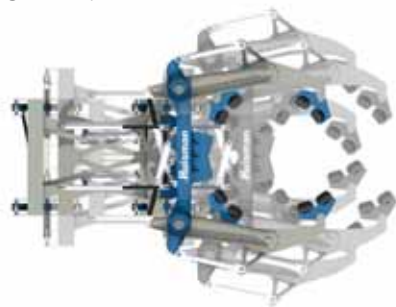

FEATURES

- Suitable for conical piles. Adjustment system keeps pile centered
- Fully opening and retracting
- Emergency release and retract mechanism, which quickly opens and retracts the gripper in case of an emergency such that the gripper or pile is not damaged
- Fully flush with side of vessel when retracted



OFFSHORE WIND

UPENDING

TRIPLE MAIN HOIST SYSTEM

The triple mainhoist system consist of three independent lowerblocks on the mainhoist position. This allows the Operator to upend heavy offshore structures such as monopoles and jackets with two hooks connected to one side, and one hook connected to the other side. The advantage is that once upended, two thirds of the crane's capacity remains available to lift the upended structure, instead of half, commonly seen with the double main hoist system.

In addition, the triple main hoist system can be used to install large and voluminous structures, such as substations and platforms, very efficiently, since a set-up with three main hook blocks allows for less rigging to be used, simplifying operations and reducing required hook height for slings and lifting gear.



UNIVERSAL LIFTING TOOL

Every saved tool exchange is avoiding a potentially dangerous situation and saving time. With this philosophy the universal lifting has been designed. A combined internal clamp allows for all major operations to be handled with one tool. The universal lifting tool is remotely operated and an on-board power pack supplies all required power.

FEATURES

- Internal pile gripper for handling monopiles (upending and lifting)
- Flange gripper to hoist transition pieces
- Spreader beam to horizontally lift piles and equipment
- Lifting eyes to attach equipment directly to slings



RETRACTABLE GRIPPER

When installing piles from a jack-up vessel the retractable gripper is used to keep the piles in the required position and keep them centralised during installation. The retractable

gripper shares the same functionality as the motion compensated gripper. The compensation frame is exchanged with a fixed frame which is able to retract the gripper.



PILING

BLUE PILING

In 2015, Huisman joined forces with Fistuca, a company developing the BLUE hammer.

Whereas conventional hydraulic hammers use a steel ram to hammer a pile, BLUE Piling Technology uses the combustion of a gas mixture under a water column to create a pressure increase. The pressure accelerates the water upwards and causes a downward force pushing the pile into the soil. The water column then falls back again, delivering a second blow. The exhaust gases are released and the cycle is repeated.

FEATURES

- **Low noise levels**

The long duration of the blow results in very low acceleration levels and low stress levels. This will reduce fatigue levels by more than 85%

- **Lower fatigue levels**

The long duration of the blow results in more pile set per blow. Combined with very low tensile forces this results in a significant decrease of the pile fatigue during installation

- **Reducing offshore operations**

The gentle blow of the BLUE Hammer will allow piles to be driven with all secondary steel attached to the pile. Boat landings, anodes and internal platforms can therefore be placed prior to driving. This will reduce offshore operations, increase safety and lower the costs of the foundations

- **Improved applicability**

BLUE Hammers can be used just like conventional impact hammers. The BLUE Hammers however have much higher energy levels resulting in an increased installation speed.

- **Increased scalability**

BLUE Piling Technology can be scaled far beyond conventional hammers, extending the maximum size of monopiles and allows for larger wind turbines and deeper waters



ASSEMBLY

CONTAINERISED SPREADER

Due to its reconfigurable design the containerised spreader can be used to hoist a large range of nacelles and other equipment up to 400mt.

FEATURES

- Fully containerised: when folded the spreader can be transported as standard 20ft container
- Space efficient: it can be folded to a compact package when not in use
- Easily adjustable rigging configuration: the spreader is adjustable in length and equipped with multiple rigging points
- Equilibrium adjustment: the position of hoisting eyes can be hydraulically adjusted to fine tune the position of the load

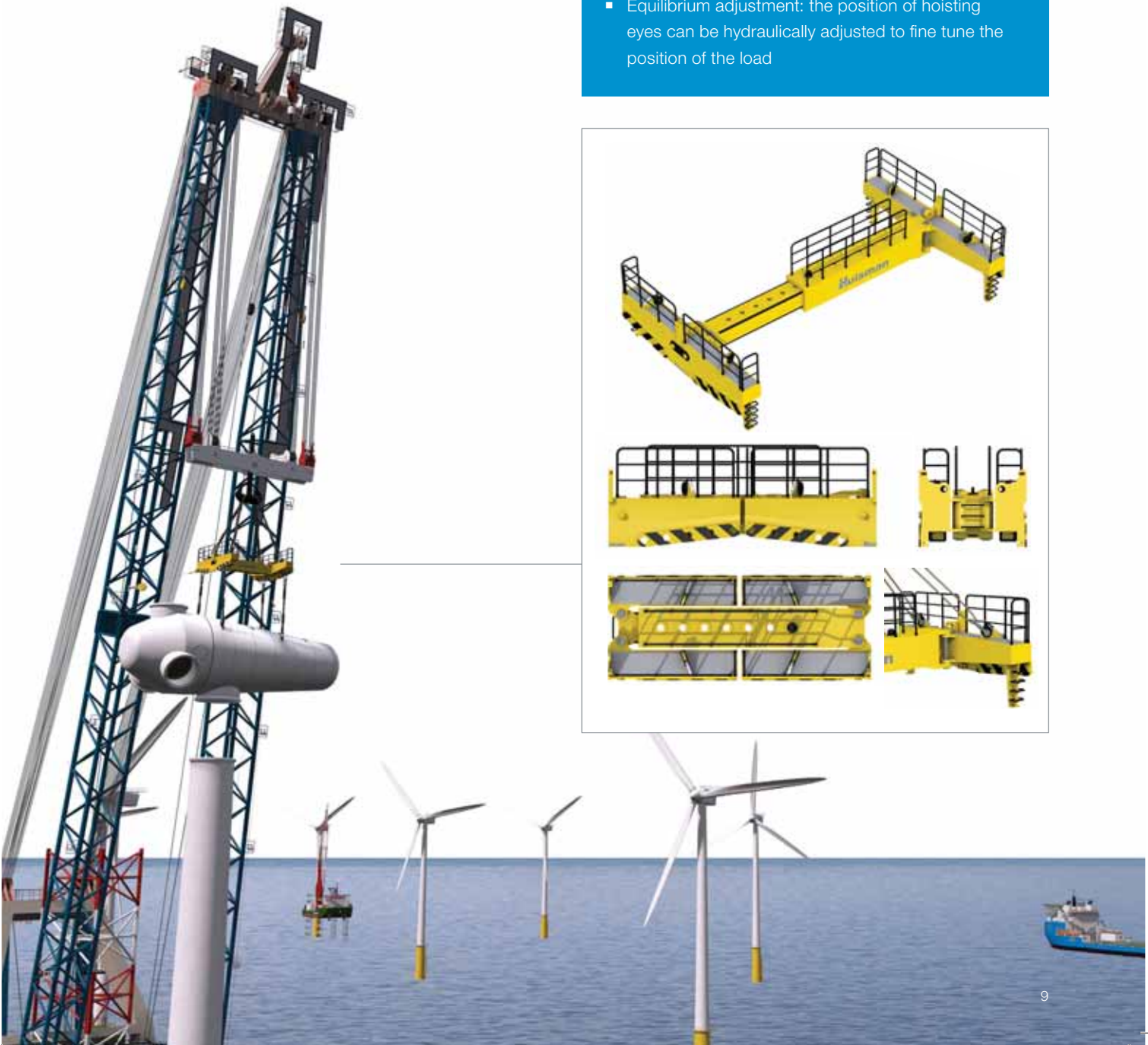

OFFSHORE WIND

CRANES

Huisman's in-house developed and manufactured cranes have been used within the offshore industry for over 30 years and have become the standard in the design and construction of heavy lift cranes. More recently, Huisman has translated its knowledge and know-how in a dedicated series of wind turbine installation and maintenance cranes. Huisman's cranes characterize in size as well as increased functionality and workability for the owner. Clever designs result in lightweight cranes with extended weather windows

and large free deck space to optimally utilize the wind turbine installation vessel. Therefore, Huisman's crane designs are very well suitable for the offshore wind turbine installation and maintenance industries. Each crane sold is a configuration of proven components and a combination of previous designs, fully adapted and tuned to our client's specific needs and operational demands. With Huisman, no single crane is the same. As a starting point, Huisman has five specific crane types suitable for the wind turbine industry:

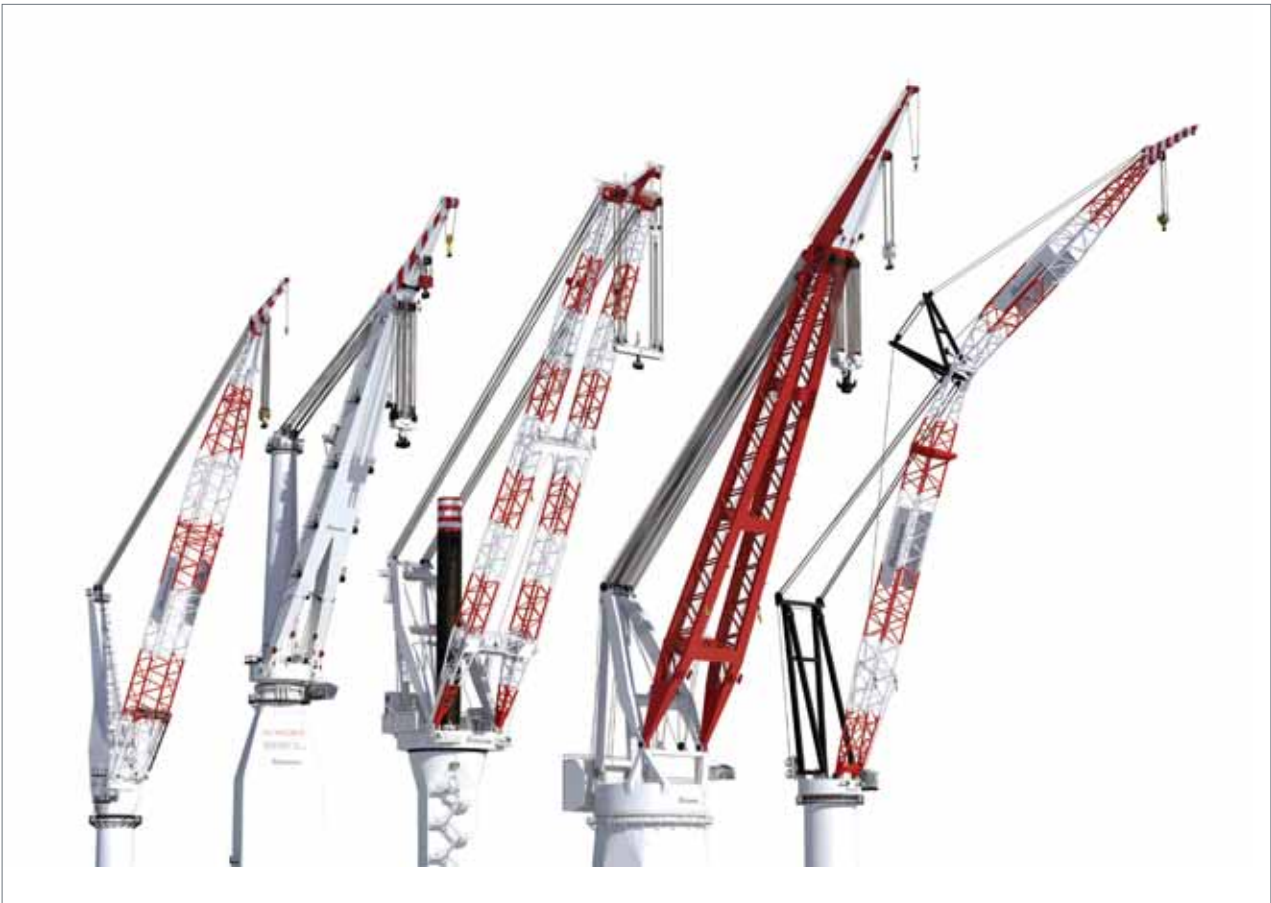

PEDESTAL MOUNTED CRANE

- Small tail swing, optimizing free deck space
- Drive system installed inside enclosed crane house, protected from the marine environment

OFFSHORE MAST CRANE

- Small footprint allows for easy integration with vessel structure, also for retrofitting on existing assets
- Small bearing diameter allows for small minimum radius and optimized free deck space
- Low CoG is ideal for installation on semi's and jack-up's

LEG ENCIRCLING CRANE

- Lightweight crane design allows for larger payload on jack-up vessels
- Small tailswing allows for optimized utilization of free deck space
- Crane range up to 2,500mt SWL

TUB MOUNTED CRANE

- Lightweight tub design
- Small tail swing, optimizing free deck space
- No counter weight
- Crane range up to 10,000mt SWL
- Ideal for extremely long boom configurations

FOLDABLE OFFSHORE CRANE

- Lightweight maintenance crane with limited SWL at over 140m lifting height above deck
- Available in leg encircling and pedestal mounted variant
- Foldable booms allow for storage on very small jack-up vessels
- Ideal for maintenance of >10MW wind turbines



OFFSHORE WIND

TELESCOPIC ACCESS BRIDGE (TAB)



Huisman closely cooperates with SMST Designers & Constructors BV, a designer and manufacturer of lifting, transportation, drilling and pipelay solutions, particularly for the maritime and offshore industry. The Telescopic Access Bridge and the Access & Cargo Towers are part of the SMST offshore wind portfolio.

TELESCOPIC ACCESS BRIDGES (TAB)

The Telescopic Access Bridge can transfer personnel safely from a vessel to an offshore structure or the quay side. Main functions of the bridge are luffing, slewing and telescoping to continuously compensate the motion and displacements of the vessel. Operation can be done by the vessel's crew and no large generator is needed which leads to a fast and inexpensive

operation. The access bridge is built in series to provide direct and worldwide availability, for both rental and purchase purposes. A range of access bridges is available (S, M, L and XL). The Telescopic Access Bridges are designed for both walk-to-work application and cargo handling. The balanced construction enables easy access to wind farms and accommodation platforms with the use of low power and minimal space requirements. The access bridges vary in length up to a maximum of 58 meter.

All the Telescopic Access Bridges are designed and built according to DNV and ABS.



FEATURES

- Focusing on safe and efficient transfer of cargo and personnel
- Modular set-up for maximizing utilization and performance
- All products available for purchase and rent

ACCESS & CARGO TOWERS

With the Access & Cargo Tower, a complete package of a tower with elevator and access bridge trolley system for safe transfer of cargo and personnel is provided. The modular setup with variable height adjustments up to 10 meter enables transport from several deck levels up to turbine platforms, at port and starboard side of the vessel, 25 meter above water level.

The Access & Cargo Tower can be expanded with a variety of motion compensated cranes and is also available as a mobile solution based on 20ft container frames to increase landing height. Low operational expenses, including power consumption of less than 100 kW, are key assets of the access system.



WIND TURBINE SHUTTLE

The vessel is especially dedicated to installing wind turbines offshore. Fully assembled wind turbines delivered to the installation site minimizes the time of construction works offshore.

The vessel is able to transport simultaneously two complete wind turbines up to an approximate size of 8MW. As the wind turbines can be fully erected, commissioned and tested onshore, the offshore commissioning time is minimized. The wind turbines will be earlier on-line and deliver power faster to the grid. The vessel can also carry and install two complete foundations (jacket type and monopiles).

The WTS is a SWATH-type vessel which provides excellent vessel motions and therefore a large workability. Since the unit is not jacked out of the water, the workability is not limited by this operation. Also no additional time is consumed by this operation.

FEATURES

- Installing complete wind turbines
- Installing complete foundations (jacket or monopile)
- Pile driving
- All year operation in the North Sea
- High yearly performance with very limited down time



TRACK RECORD



SCYLLA

1,500mt Leg Encircling Crane onboard Seajacks' offshore wind farm installation vessel Scylla



HUISMAN EQUIPMENT BV

Admiraal Trompstraat 2
3115 HH Schiedam
Postbus 150
3100 AD Schiedam
The Netherlands

Telefoon: 088 070 22 22

Fax: 088 070 22 22

E-mail: info@huisman-nl.com

www.huismanequipment.com

